

LEMO[®]
Electronic & Fiber Optic Connectors

HERMAPRODITIC PUSH-PULL CONNECTORS

Dear Customers,

As far as data transmission is concerned, the superior characteristics of fibre optics compared to electrical cables are clearly recognised today.

The advantages of fibre optics include a transmission capacity 10 times greater than that of conventional coaxial cables, in only one tenth of the size. The reduced weight and space requirements make handling and line installation much easier. Furthermore, fibre optics is characterized by low signal amplitude loss, no susceptibility to electromagnetic interference, and an absence of interference between neighbouring lines. It also offers greater security due to the difficulty of intercepting optical signals.

The growing number of applications is more and more varied, and the annual growth rate of fibre optics is greater than 10%. Current applications of fibre optics include: telemetry, process control, data transmission, cable and closed circuit television, as well as laser signal transmission in medical applications.

However, most systems equipped with fibre optics also require simultaneous electrical energy for control operations and power supply. Current practice involves the use of separate electrical and fibre optic connectors.

The new technology developed by LEMO greatly simplifies this practice by combining electrical and fibre optic signals in a single connector.

LEMO can now offer you a full range of mixed electrical/fibre optic connectors for singlemode or multimode transmission. This product range is available with metal or plastic outer shells, as well as in a watertight version.

The range is completed by the addition of a single channel fibre optic connector series. All LEMO fibre optic connectors use a plug and socket push-pull self-latching connection system, obviating the need for plug to plug adaptors. This is a major advantage of the LEMO technology over its competitors.

With the aim of providing the best possible answers to your fibre optic needs, LEMO has established an important research and development facility to provide quick and effective solutions to your design requirements.

LEMO ISO 9001 certified has been improving its "quality culture" with the aim of reaching TQM. Offering zero defect products with due regard to the environment and meeting delivery requirements, are LEMO's two main concerns.



LEMO SA
General Management



1 Coaxial Series 00 & 01 Connectors



2 Unipole & Multipole Connectors



5 Fibre Optic Connectors



8 Audio-Video Catalogue

SH-MH Series

The LEMO Hermaphroditic series provide a rugged high performance patented push-pull hermaphroditic interconnection system. These «genderless» connectors combine LEMO's well proven push-pull latching technology and the use of our standard high quality optical and electrical contacts.

The main features of these series are as follow:

- security of a new patented push-pull hermaphroditic self-latching system
- 2 shell sizes, SH and MH series
- compact unsealed version for general purpose applications
- rugged waterproof (IP 68) version for all outdoor applications
- a choice of multifibre or electrical contacts configurations
- lightweight design with shell in anthracite nickel-plated aluminium alloy
- low loss ceramic PC technology in multimode and singlemode
- gold plated electrical contacts.

Each series consists of plug and socket which will accept cable diameter ranging from 3.6 mm to 10 mm. Initial program is giving solutions with 2, 4 or 6 fibre optic channel and 6 or 12 electrical contacts.

Interconnections

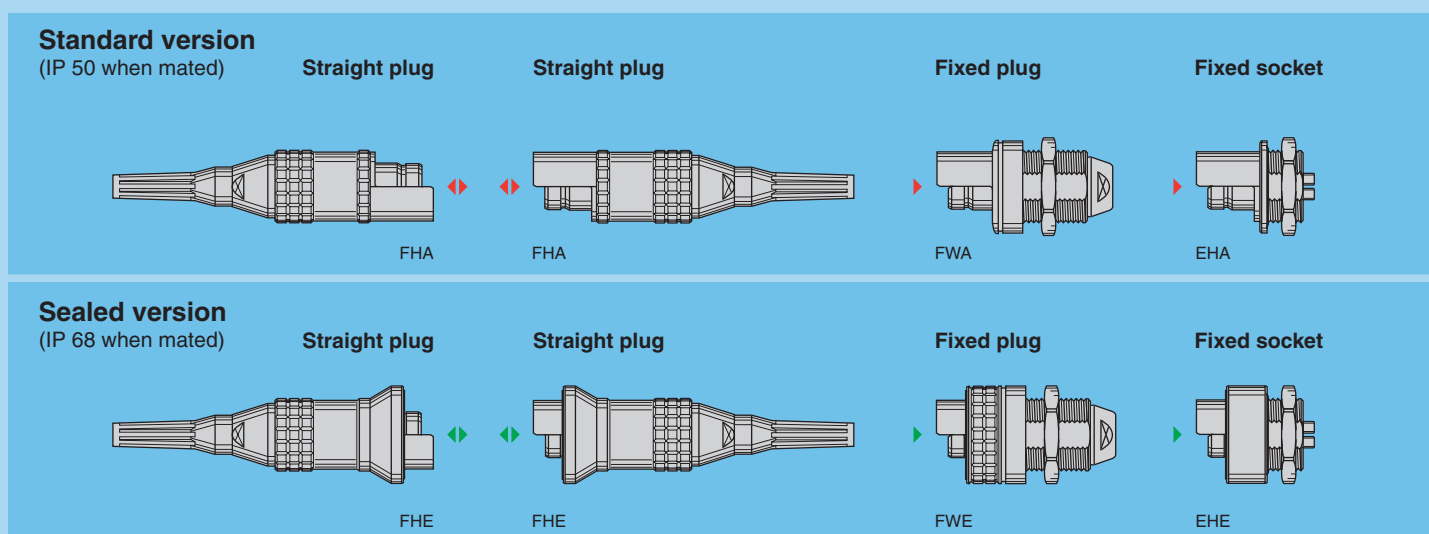

Model Description

FHA Straight plug with cable adapter or collet and nut with bend relief

FHE Straight plug with cable adapter or collet and nut with bend relief (IP 68 when mated)

FWA Fixed plug, nut fixing

FWE Fixed plug, nut fixing (IP 68 when mated)

EHA Fixed socket, nut fixing

EHE Fixed socket, nut fixing (IP 68 when mated)

Part Section Showing Internal Components

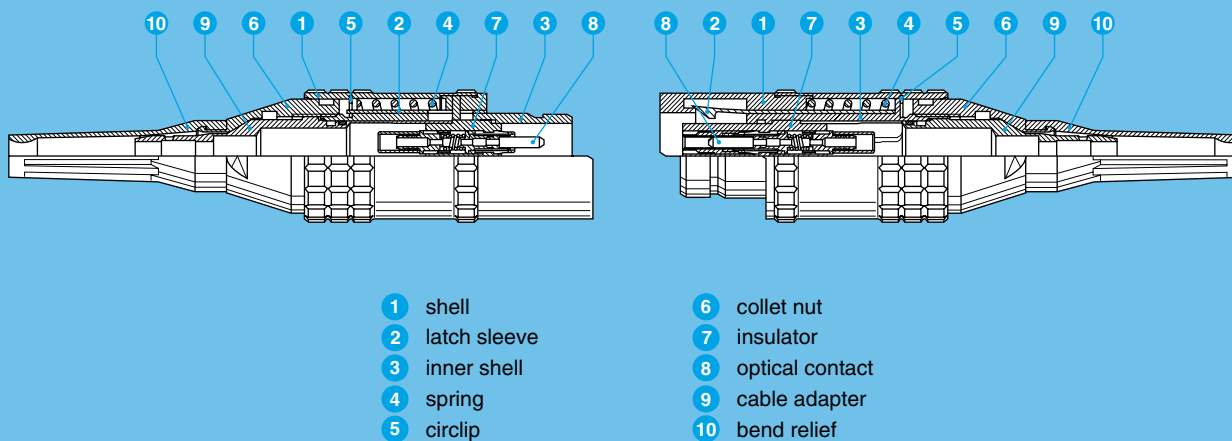

Technical Characteristics

Mechanical and Environmental

Characteristic	Value	Standard
Mating durability	2000 cycles	IEC 60512-5 test 9a
Temperature range	-55°C to +125°C	
Vibration resistance	10-2000 Hz, 15g	IEC 60512-4 test 6d
Shock resistance	100 g, 6 ms	IEC 60512-4 test 6c
Protection index FHE/FHE	IP 68	IEC 60529
Water immersion FHE/FHE	up to 2 meters depth	
Protection index FHA/FHA	IP 50	IEC 60529
Average latching retention	SH series plug/plug	600 N
	SH series plug/socket	300 N
	MH series plug/plug	800 N
	MH series plug/socket	400 N
		IEC 60512-8 test 15f

Electrical

Characteristic	Value	Standard
Insulation resistance	> 10 ¹² Ω	IEC 60512-2 test 3a
Contact resistance	< 3.6 mΩ	IEC 60512-2 test 11f
Shell resistance	< 10 mΩ	IEC 60512-2 test 2f

Optical

Characteristic	Value	Standard	Method
Average insertion loss fibre 9/125 µm	0.18 dB	IEC 61300-03-34	Method 2
Average insertion loss fibre 50/125 µm	0.25 dB	IEC 61300-03-34	Method 2
Return loss fibre 9/125 µm (UPC)	≥45 dB	IEC 61300-03-06	Coupler Method
Return loss fibre 9/125 µm (Hand polish)	>25 dB	IEC 61300-03-06	Coupler Method

Materials and Treatments

Component	Material (Standard)	Surface treat (µm)		
		nickel		
		Cu	Ni	Au
Outer shell, collet nut ¹⁾	Aluminium alloy (AA 6262A)	–	5	–
Latch sleeve	Special brass	0.5	3	–
Other metallic parts	Aluminium alloy (AA 6262A)	–	5	–
Spring	Stainless steel	without treatment		
Insulator	PEEK	without treatment		
Electrical contacts	Brass (male)/Bronze (female)	0.5	3	1
O-ring and gaskets	Silicone MQ / MVQ	without treatment		

Notes: 1) anthracite colour

Part Number Example

A different part number structure is applicable for each of the following product types:

– Plugs and fixed sockets; fibre optic contacts.

Note: The fibre optic contacts must be ordered separately. An equal number of contacts must be ordered (eg. for MH.03C; 2 x FFS.F2 and 2 x PSS.F2).

Straight plug with bend relief

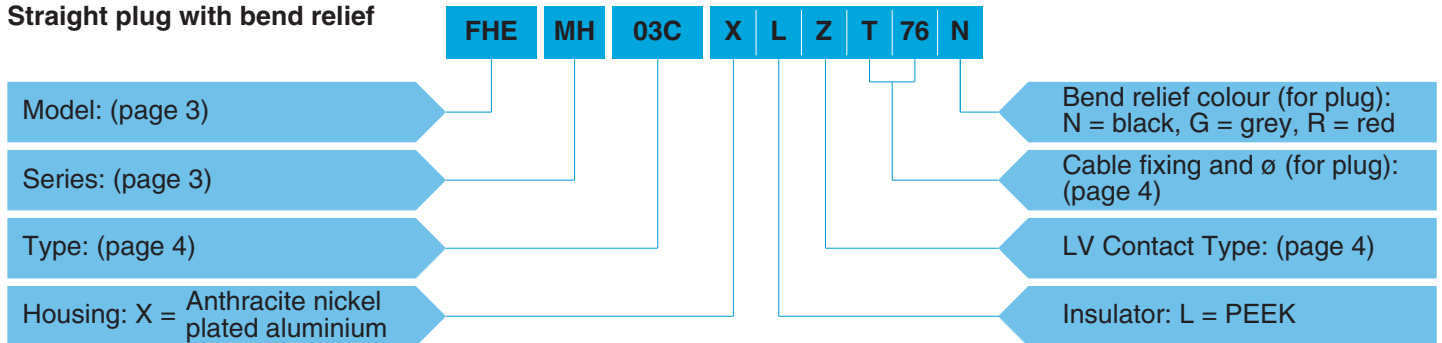

FHE.MH.03C.XLZT76N = Straight plug (IP 68 when mated), MH series, multifibre to accept 4 F2 type fibre optic contacts, anthracite nickel plated aluminium shell, PEEK insulator, with cable fixing type T for 7.5 to 6.6 mm cable and black bend relief.

Fiber optic contact

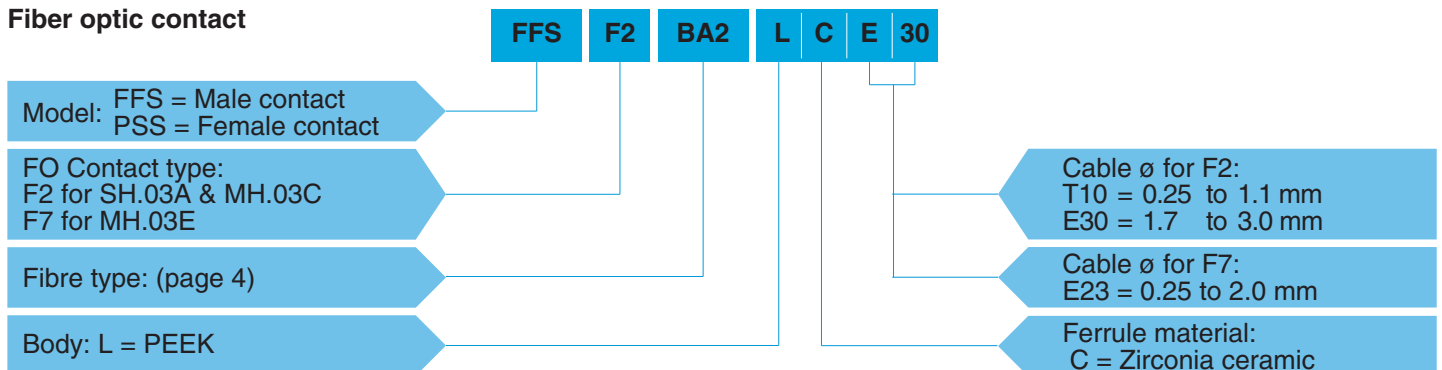

FFS.F2.BA2.LCE30 = Male F2 type fibre optic contact, ferrule bore diameter of 125 µm, PEEK body, Zirconia ceramic ferrule, crimp cable fixing, for tight jacket cable with a diameter between 1.7 to 3.0 mm.

Models - Series

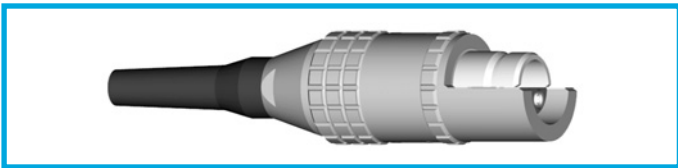

FHA Straight plug with cable adapter or collet and nut with bend relief

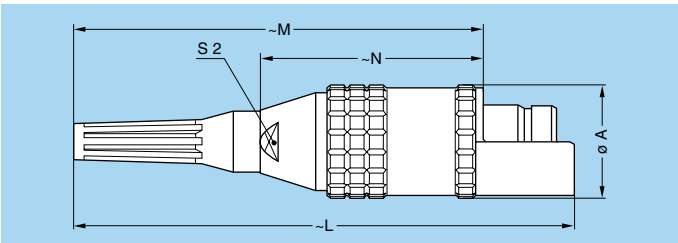

Reference		Dimensions (mm)				
Model	Series	A	L	M	N	S2
FHA	SH	21.8	98.4	82.2	46.2	13
FHA	MH	25.4	109.3	89.1	47.1	15

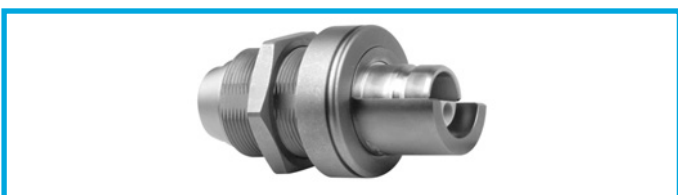

FWA Fixed plug, nut fixing

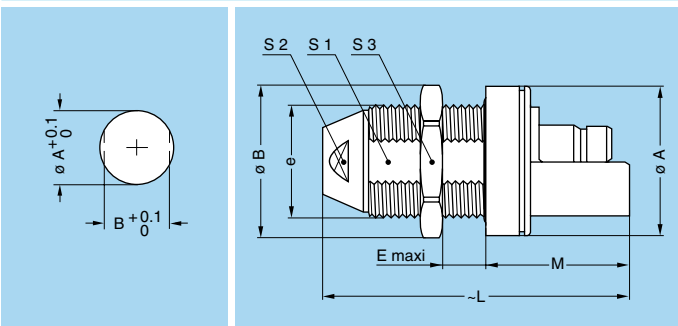

Reference		Dimensions (mm)								
Model	Series	A	B	e	E	L	M	S1	S2	S3
FWA	SH	28.5	28.5	M22x1	14	55.0	26.5	20.5	14	25
FWA	MH	34.0	34.0	M25x1	17	64.5	31.5	23.5	17	30

Panel cut-outs

Series	Dim. (mm)	
	ø A	B
SH	22.2	20.6
MH	25.2	23.6

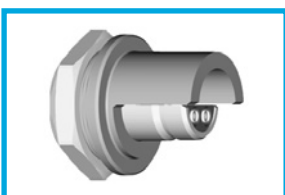

EHA Fixed socket, nut fixing

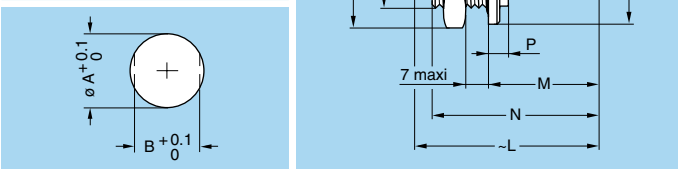

Reference		Dimensions (mm)									
Model	Series	A	B	e	L		M	N	P	S1	S3
					optic	elect.					
EHA	SH	27	28.5	M22x1	38.8	30.5	19.5	30.5	3.3	20.5	25
EHA	MH	32	34.0	M25x1	40.8	37.0	24.5	37.0	4.3	23.5	30

Panel cut-outs

Series	Dim. (mm)	
	ø A	B
SH	22.2	20.6
MH	25.2	23.6

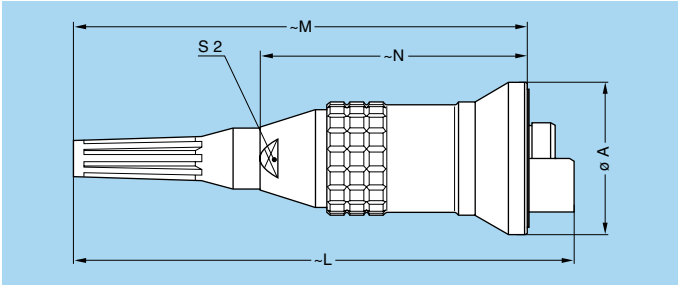
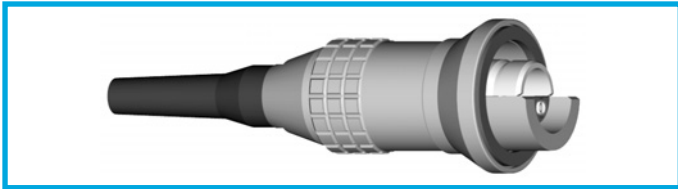

FHE Straight plug with cable adapter or collet and nut with bend relief (IP 68 when mated)

Reference		Dimensions (mm)				
Model	Series	A	L	M	N	S2
FHE	SH	28.5	98.4	90.0	54.0	13
FHE	MH	34.0	109.3	98.9	56.9	15

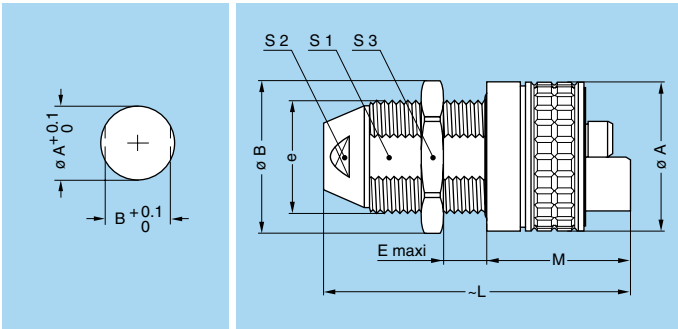
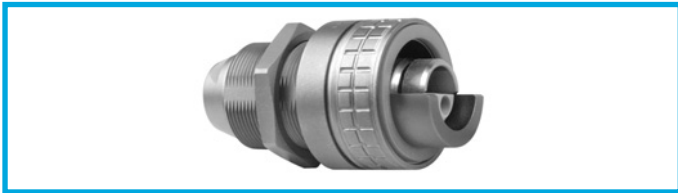

FWE Fixed socket, nut fixing (IP 68 when mated)

Reference		Dimensions (mm)								
Model	Series	A	B	e	E	L	M	S1	S2	S3
FWE	SH	28.5	28.5	M22x1	14	55.0	26.5	20.5	14	25
FWE	MH	34.0	34.0	M25x1	17	64.5	31.5	23.5	17	30

Panel cut-outs

Series	Dim. (mm)	
	ø A	B
SH	22.2	20.6
MH	25.2	23.6

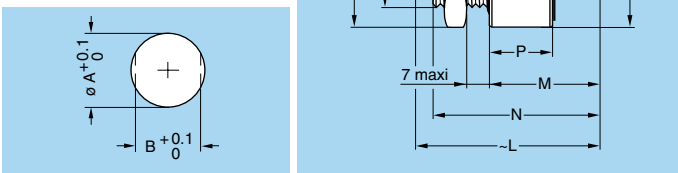
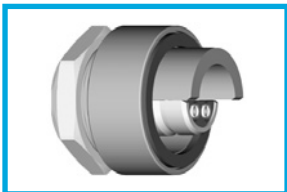

EHE Fixed socket, nut fixing (IP 68 when mated)

Reference		Dimensions (mm)									
Model	Series	A	B	e	L		M	N	P	S1	S3
					optic	elect.					
EHE	SH	28.5	28.5	M22x1	38.8	30.5	19.5	30.5	11.1	20.5	25
EHE	MH	34.0	34.0	M25x1	40.8	37.0	24.5	37.0	14.1	23.5	30

Panel cut-outs

Series	Dim. (mm)	
	ø A	B
SH	22.2	20.6
MH	25.2	23.6

Type

	Plug	Socket	Reference	FO contact		Low Voltage contact						
				F2 Nb	F7 Nb	Contact Nb	ø A (mm)	Contact type		Test voltage (kV rms)	Test voltage (kV dc)	Rated current (A)
								AWG max	AWG			
	Solder	Crimp										
SH			03A	2	-	-	-	-	-	-	-	
			306	-	-	6	1.3	20	18-20	1.5	2.1	12
MH			03C	4	-	-	-	-	-	-	-	
			03E	-	6	-	-	-	-	-	-	
			312	-	-	12	1.3	20	18-20	1.0	1.5	8

Note: Other arrangement, optical, electrical or mixed optical-electrical can be made available upon request.

WARNING: There is no contact number on the insulator. When wiring one hermaphroditic connector, one should terminate each contact to its mirror image number of the other connector.

Electrical contact

Reference	Contact type
A	solder for plug
C	crimp for plug
L	solder for socket
M	crimp for socket
Z	no contact

Cable diameter

	Adapter «T» for fibre optic connectors			Collet «C» for electrical connectors		
	Ref.	Cable ø		Ref.	Cable ø	
		max	min		max	min
SH	T46	4.5	3.6	C52	5.0	4.1
	T56	5.5	4.6	C62	6.0	5.1
	T66	6.5	5.6	C72	7.0	6.1
	T76	7.5	6.6	C82	8.0	7.1
MH	T56	5.5	4.6	C62	6.0	5.1
	T66	6.5	5.6	C72	7.0	6.1
	T76	7.5	6.6	C82	8.0	7.1
	T86	8.5	7.6	C92	9.0	8.1
	T91	9.0	8.6	C10	10.0	9.1

Fibre type

Reference for F2 contact	Reference for F7 contact	ø Core/Cladding (µm)	Ferrule hole ø (µm)	Note
BA2	125	9/125	125	●
BB2	126	50/125	126	●
BD2	128	62.5/125	128	○

● First choice alternative ○ Special order alternative

Accessories

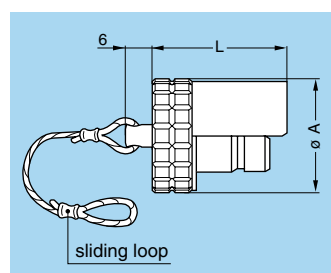

BFA Cap (for FHA and FWA plugs)

Part number	Dim. (mm)	
	A	L
BFA.SH.100.XAZ	21.8	23.5
BFA.MH.100.XAZ	25.4	30.0

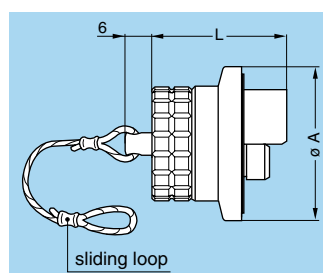

BFE Cap (for FHE and FWE plugs)

Part number	Dim. (mm)	
	A	L
BFE.SH.100.XAS	28.5	23.5
BFE.MH.100.XAS	34.0	30.0

Tooling

A complete range of tools for electrical or fibre optic connector cable assembly is available. Consult our specific catalogs.